

RAL SERIES

An innovative electric actuator based on patented technology which provides an ultra-efficient solution to a wide range of applications. With a configurable stem shear torque allowing maximum safety factor in any application. Reliable customer driven quality with a wide range of configurable features.

FEATURES

- Maximum Allowable 'Stem Torque' to protect valve
- Feedback on minimum amount of 'Stem Torque'
- Automatic configuration
- Real time data (cycles, temp, number of starts, power on/off, etc.)
- Failsafe activation
- Fault codes
- Status of valve deterioration
- Status of possible blockages
- Graphical Dashboard feature
- Reduces downtime with live information actuator controller system
- ISO 9001: 2015 accredited company



SPECIFICATIONS

| | |
|--------------------------------|------------------------------|
| Product Model No.: | RAL200UV |
| Torque: | Up to 200Nm |
| Weight: | 3.6 Kg |
| Working Time 0-90°: | 16 Seconds |
| Anti-condensation Heater: | 5 Watts |
| Cable Entries: | 2 x 20mm Cable Glands |
| ISO5211 Mounting: | F07, F10 |
| Output Drive Square: | 17 mm |
| Output Drive Orientation: | 0/45° |
| Ingress Protection: | IP67 |
| Input Voltage: | 12V–30V DC/80V–300V AC |
| End of Travel Relays (2): | 250VAC/5A – 30VDC |
| Ambient Temp Range °C: | -20 to +70 |
| Manual Override: | Local Buttons |
| Bluetooth Control: | Via Android App |
| Visual Position Indicator: | Visual Positional LEDs |
| Electronic Position Indicator: | Via Bluetooth App |
| Reverse Acting: | Close CCW |
| Calibration Mode: | Open/Closed Position & Angle |

CHARACTERISTICS

| | |
|-------------------|---------------------------|
| Base: | Nylon 66 GF30 |
| Top: | Nylon 66 GF30 |
| Gears: | Acetal and Nylon 66 |
| External Screws: | Stainless Steel |
| Electrical Motor: | Single Phase 6-24V DC |
| Drive Adapter: | Aluminium 608LT6 |
| CE Conformance: | EN 15714-2; IP67; ISO5211 |

OUTLINE DIMENSIONS

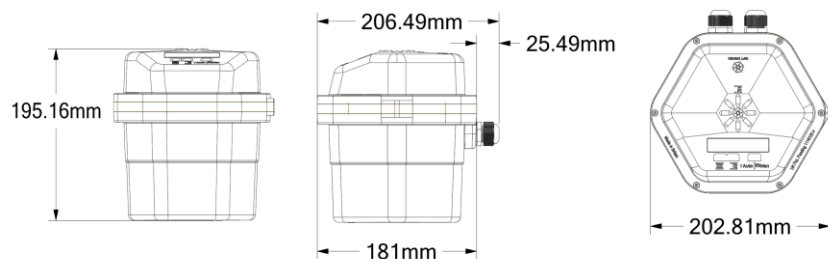

OPTIONAL FEATURES

- Speed Control
- Failsafe – NC, NO, Stay Put, Specific Angle
- Multi-Turn - 360°
- Modulation/Process Control – 4-20mA, 0-20mA, 0-10V
- Modulating Loss of Signal – Close, Open, Stay Put, Specific Angle
- Wiggle – Angle/Frequency
- Off Grid Capability
- Custom Drive Adapter

BENEFITS

- Easy Setup
- Energy Efficient
- Plug-in Connectors
- Bluetooth Connectivity
- Accuracy to within 0.5°
- Rugged construction for extended service life
- ISO5211 mounting
- Fits most commercial valves

ADDITIONAL SERVICES

- Customised Design
- Field Set-up
- Technical Support
- Application Support
- Guaranteed Warranty

CONNECTIONS

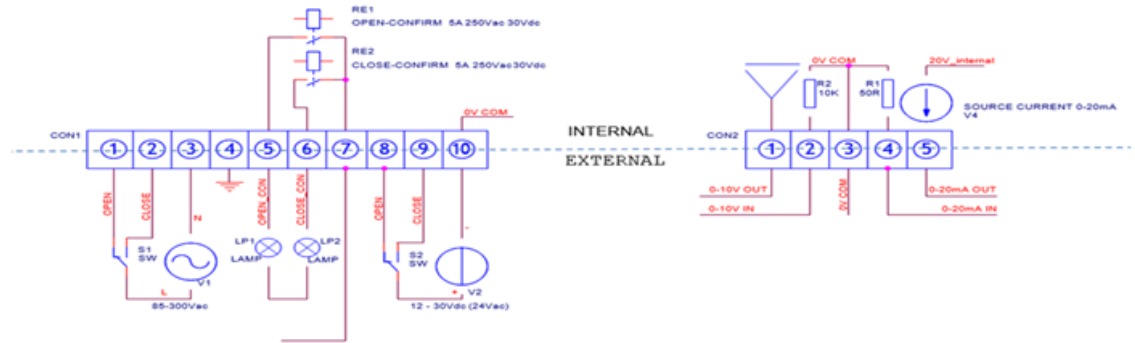

ISOMETRIC VIEW

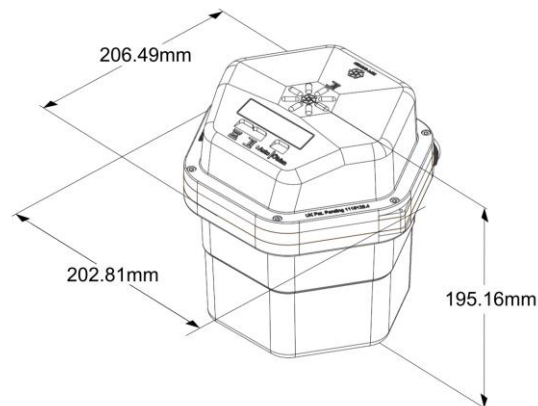

PART NUMBER CONFIGURATION

| RAL | 40 | - | L | F03 | A | P | - | A | 4 | WA | - | 001 |
|-----|---|---|---|-----|---|---|---|---|--|----|---|-----|
| | ① | | ② | ③ | ④ | ⑤ | | ⑥ | ⑦ | ⑧ | | ⑨ |
| ① | Stem shear torque 100: 100Nm 200: 200Nm ... | | | ④ | Drive Adapter A: 17mm B: 22mm C: Custom | | | ⑦ | Speed 16 / X | | | |
| ② | Voltage L: 10-30DC H: 80-300VAC | | | ⑤ | Failsafe Option P: Open L: Close G: Angle | | | ⑧ | Wiggle WA: angle WT: interval | | | |
| ③ | Mounting Option F07 / F10 | | | ⑥ | Modulation A: 0-10V B: 0-20mA C: 4-20mA | | | ⑨ | Customs/ factory code | | | |

RIFT ACTUATORS

UK Office: Shaw House, 110-114 Barnard Green Road, Malvern, Worcester, UK. WR14 3ND
 Email: sales@rifactuators.com. Phone: +44 (0) 1684.386.523

USA Office: Katy, Texas. USA. 77494
 Email: usa@rifactuators.com Phone: +1 713.839.5041

Website: www.rifactuators.com

23/11/2020 v1.3