

Product Description

An innovative electric actuator based on patented technology which provides an ultra-efficient solution to a wide range of applications. With a configurable stem shear torque allowing maximum safety factor in any application. Reliable customer driven quality with a wide range of configurable features.



Features

- Maximum Allowable 'Stem Torque' to protect valve
- Feedback on minimum amount of 'Stem Torque'
- Automatic configuration
- Real time data (cycles, temp, number of starts, power on/off, etc.)
- Failsafe activation
- Fault codes
- Status of valve deterioration
- Status of possible blockages
- Graphical Dashboard feature
- Reduces downtime with live information actuator controller system
- ISO 9001: 2015 accredited company

Operational Features

- Speed Control
- Failsafe – NC, NO, Stay Put, Specific Angle
- Multi-Turn - 360°
- Modulation/Process Control – 4- 20mA, 0-20mA, 0-10v
- Modulating Loss of Signal – Close, Open, Stay Put, Specific Angle
- Wiggle – Angle/Frequency
- Off Grid Capability
- Custom Drive Adapter

Outline Dimensions



Specifications

Product Model No	RAM100UV
Torque	Up to 100Nm
Weight	2.2 Kg
Working Time 0-90°	4 Seconds
Anti-condensation Heater	5 Watts
Cable Entries	2 x 20mm Cable Glands
ISO5211 Mounting	F03, F04, F05, F07 & F10
Output Drive Square	14mm & 17 mm
Output Drive Orientation	0/45°
Ingress Protection	IP67
Input Voltage	12V–30V DC/80V–300V AC
End of Travel Relays (2)	250VAC/5A – 30VDC
Ambient Temp Range °C	-20 to +70
Manual Override	Local Buttons
Bluetooth Control	Via Android App
Visual Position Indicator	Visual Positional LEDs
Electronic Position Indicator	Via Bluetooth App
Reverse Acting	Close CCW
Calibration Mode	Open/Closed Position & Angle

Characteristics

Base	Nylon 66 GF30
Top	Nylon 66 GF30
Gears	Acetal and Nylon 66
External Screws	Stainless Steel
Electrical Motor	Single Phase 6-24V DC
Drive Adapter	Nylon 66 GF30
CE Conformance	EN 15714-2; IP67; ISO5211
Battery	Internal Lithium-Ion Battery

Connections

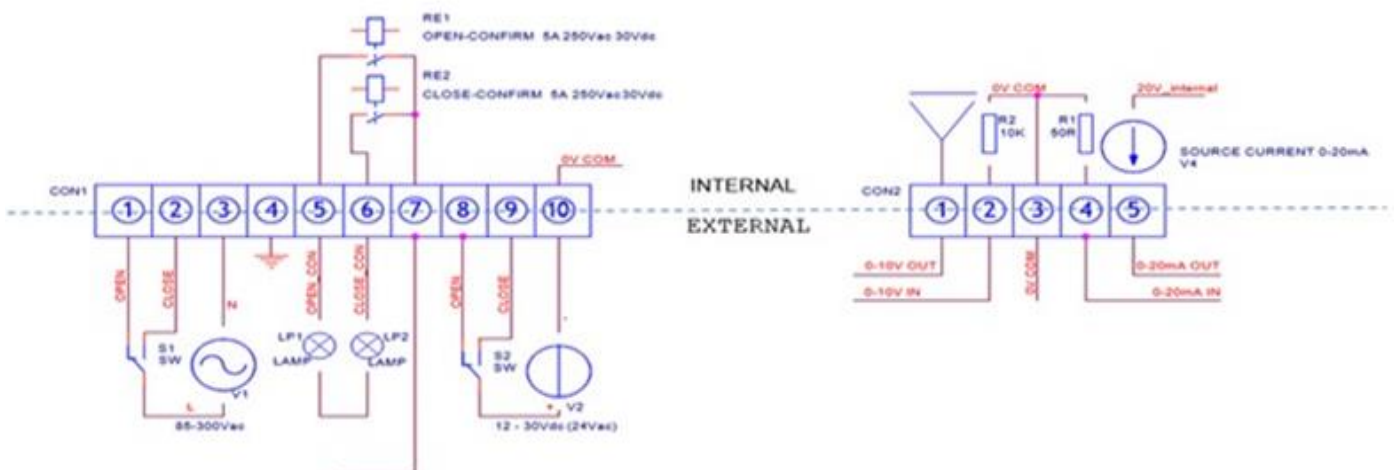

Isometric view

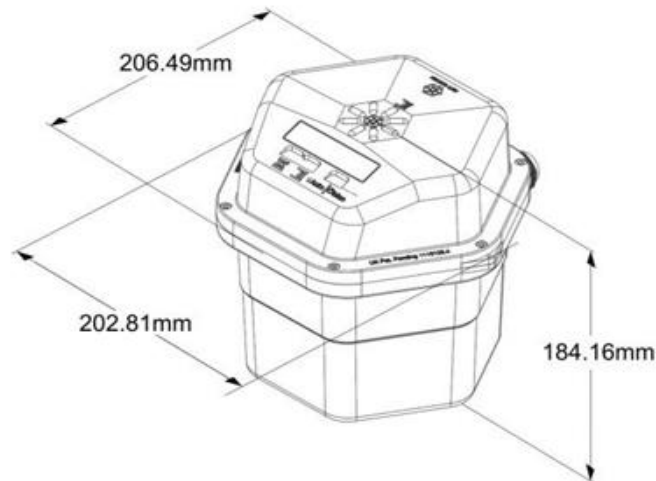

Part Number Configuration

RAM	40	-	L	F03	A	P	A	4	WA	-	001
	①		②	③	④	⑤	⑥	⑦	⑧		⑨
①	Stem shear torque			④	Drive Adapter		⑦	Speed			
	40: 40Nm 60: 60Nm 80: 80Nm 100: 100Nm				A: 14mm E: 22MM B: 17mm F: Custom C: 9mm D: 11mm			4 / 8 / 12/16/X			
②	Voltage			⑤	Failsafe Option		⑧	Wiggle			
	L: 10-30DC H: 80-300VAC				P: Open L: Close G: Angle			WA: angle WT: interval			
③	Mounting Option			⑥	Modulation		⑨	Customs/ factory code			
	F03 / F04 / F05/ F07/F10				A: 0-10V B: 0-20mA C: 4-20mA						

Benefits

- Easy Setup
- Energy Efficient
- Plug-in Connectors
- Bluetooth Connectivity
- Accuracy to within 0.5°
- Rugged construction for extended service life
- ISO5211 mounting
- Fits most commercial valves

Additional Services

- Customized Design
- Field Set-up
- Technical Support
- Application Support
- Guaranteed Warranty

UK Office: Shaw House, 110-114 Barnards Green Road, Malvern, Worcester, UK. WR14 3ND
Email: sales@riffactuators.com. Phone: +44 (0) 1684.368.523

USA Office: Katy, Texas. USA. 77494
Email: usa@riffactuators.com Phone: +1 713.839.5041